

## Drop-In

### Drop-in remote refrigerated well with refrigerated display, compact (2 GN container capacity)

ITEM # \_\_\_\_\_

MODEL # \_\_\_\_\_

NAME # \_\_\_\_\_

SIS # \_\_\_\_\_

AIA # \_\_\_\_\_

**341122 (D19R2)**

Drop-in remote refrigerated well with refrigerated display, compact (2 GN container capacity)

### Short Form Specification

#### Item No.

Designed to be positioned in flush installation providing improved cleanability and suitable for modern design installations. Designed to serve: Plates on the shelves and food in GN containers or food on plates/packages or bottles and cans thanks to adjustable bottom well. Suitable for GN 1/1 containers with a maximum height of 200 mm. Food introduced at the correct temperature maintains its core temperature according to Afnor Standards. Automatic defrosting guarantees evaporators clearance and efficient well cooling. Digital control with temperature display with precise adjustment (0,1° C). Fully compliant HACCP digital controls include visible alarms. The unit is composed of two refrigeration systems: a static cooled well on the bottom and evaporator with fan on the top. Bottom well is designed to serve the food in GN containers or bottles and cans. Short sides and the top are in double glazed low emission glass (18 mm thick) to improve insulation avoiding formation of the condensation and reducing energy consumption. The display is illuminated by inside LED light under each glass shelf that emphasizes the cold food colors. The temperature uniformity is guaranteed by fans and an high surface evaporator placed at the top of the unit. The configuration allows a compact footprint and excellent preservation performances. Plexiglass display case with lift-up doors on both sides to ensure maximum hygiene of the food. Includes 2 adjustable shelves composed of two grids each. The shelves can be adjusted in height to allocate different items. Wells in 304 AISI stainless steel with rounded corners to facilitate cleaning operations. The well is also equipped with a drain hole.

High-density expanded polyurethane foam with cyclopentane guarantees excellent well insulation to reduce energy dispersion. Preadjusted connection to remote cooling unit (not included). Refrigerant type R452a other gases are available on request.

### Main Features

- Preadjusted connection to remote cooling unit (not included).
- CB and CE certified by a third party notified body.
- Designed to be positioned in flush installation providing improved cleanability and suitable for modern design installations.
- Suitable for GN 1/1 containers with a maximum height of 200 mm.
- Precise temperature control and setting at 0,1°C .
- As standard the product comes with digitally controlled thermostat which is in line of HACCP norms and provides visual alarm as a warning of the increasing or decreasing temperatures.
- Available drop-in dimensions: 2, 3, 4 GN.
- Food introduced at the correct temperature maintains its core temperature according to Afnor Standards.
- Automatic defrosting guarantees evaporators clearance and efficient well cooling.
- The unit is composed of two refrigeration systems: a static cooled well on the bottom and evaporator with fan on the top.
- Bottom well is designed to serve the food in GN containers or bottles and cans.
- The temperature uniformity is guaranteed by fans and an high surface evaporator placed at the top of the unit.
- The configuration allows a compact footprint and excellent preservation performances.
- Plexiglass display case with lift-up doors on both sides to ensure maximum hygiene of the food.
- Includes 2 adjustable shelves composed of two grids each. The shelves can be adjusted in height to allocate different items.
- The display is illuminated by inside LED light under each shelf that emphasizes the cold food colors.
- Built-in cooling unit version is available.

### Construction

- Well bottom is inclined to facilitate water drainage.
- Environmentally friendly: R452a as refrigerant gas.
- Well in 304 AISI stainless steel with rounded corners to facilitate cleaning operations. The well is also equipped with a drain hole.
- Electronic control with temperature display.
- IPx2 water protection.

### Sustainability

- High-density expanded polyurethane foam with cyclopentane guarantees excellent well insulation to reduce energy dispersion.
- Short sides and the top are in double glazed low emission glass (18 mm thick) to improve insulation avoiding formation of the condensation and

APPROVAL: \_\_\_\_\_

reducing energy consumption.



Rear side

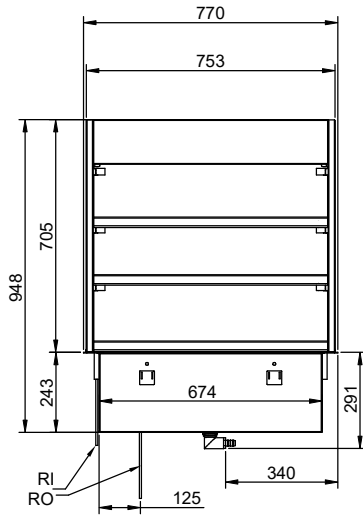

Side

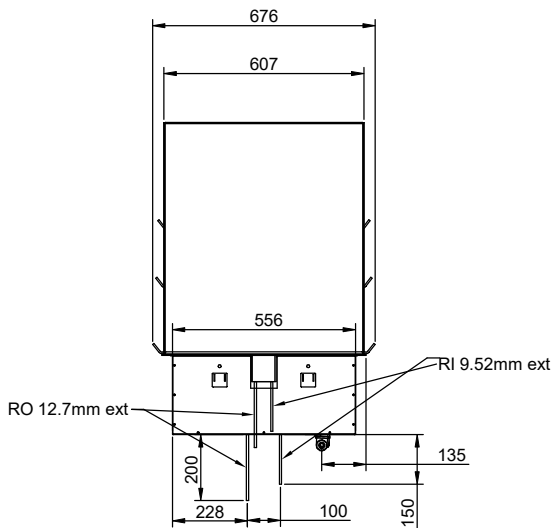

D = Drain  
 EI = Electrical inlet (power)  
 RI = Refrigerant Inlet

Top

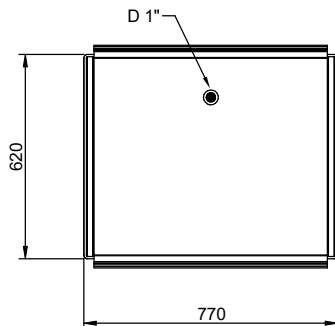

### Electric

Supply voltage:  
 341122 (D19R2) 220-240 V/1N ph/50 Hz  
 Electrical power max.: 0.07 kW

### Water:

Water drain outlet size: 1"

### Key Information:

External dimensions, Width: 770 mm  
 External dimensions, Depth: 620 mm  
 External dimensions, Height: 950 mm  
 Net weight: 106.5 kg  
 Shipping weight: 119.5 kg  
 Shipping height: 1070 mm  
 Shipping width: 660 mm  
 Shipping depth: 810 mm  
 Shipping volume: 0.57 m<sup>3</sup>  
 Set temperature: +4 / +8 °C

### Refrigeration Data

Refrigerant type: R452A  
 Connection pipes (remote) - outlet: 12.7 mm  
 Connection pipes (remote) - inlet: 9.52 mm

### Sustainability

Noise level: 0 dBA

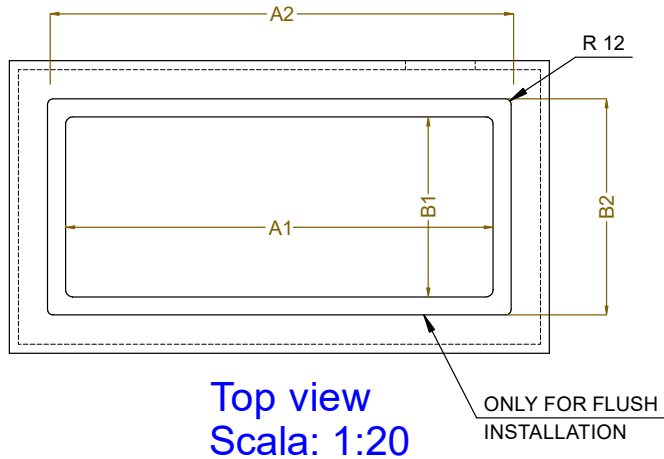
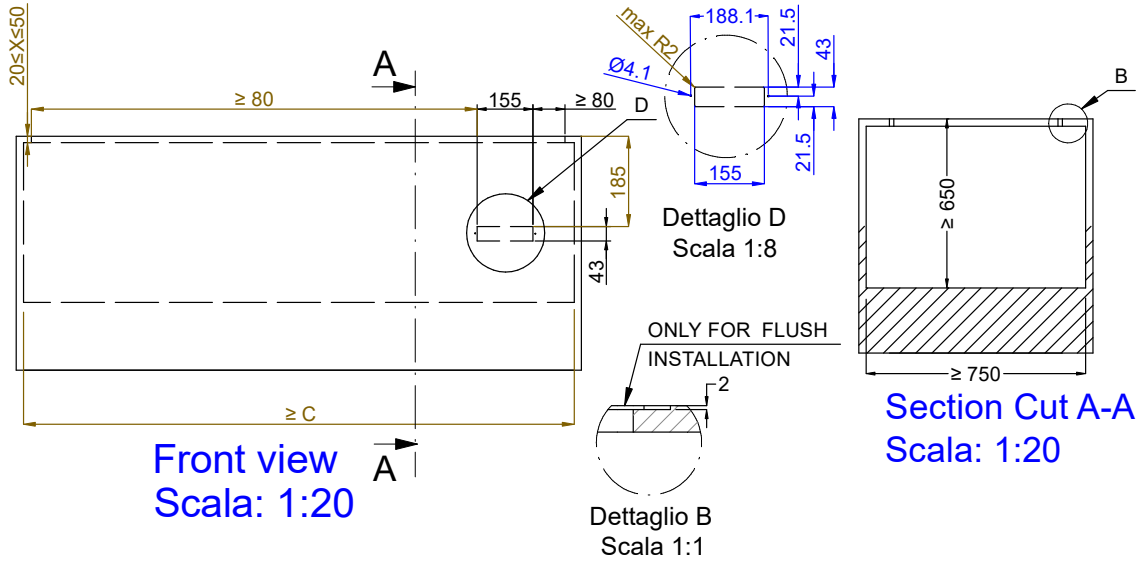

CAPACITY	CUTOUT		LOWERING FOR FLUSH INSTALLATION		C
	A1	B1	A2	B2	
2GN	700		774		880
3GN	1030	580	1104	624	1200
4GN	1350		1424		1530

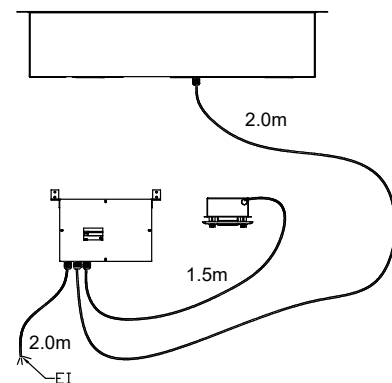
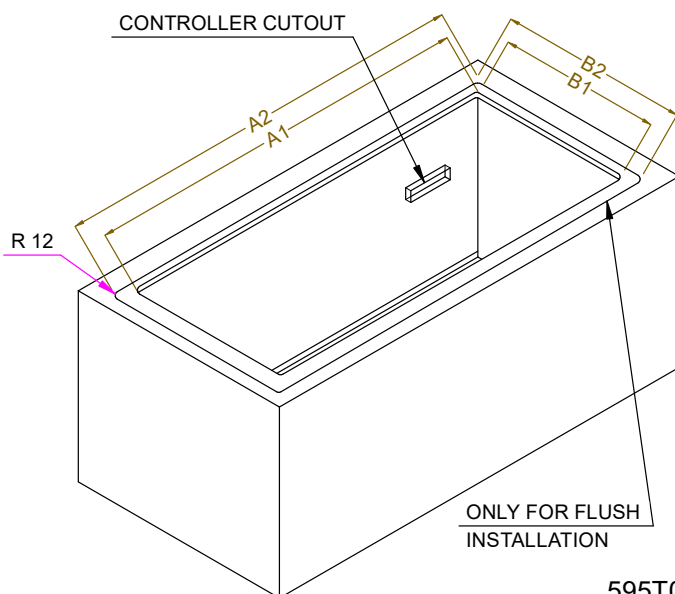

595T01Y00 - COLD COMPACT DISPLAY REM.